

## FREE SPEC 2-INPUT ARITHMETIC AND LOGIC UNIT

We thank you for purchasing the product manufactured by Watanabe Electric Industry Co., Ltd. Please use the product in accordance with this manual after confirming that the contents on the rating label of the product conform to the specifications you required.

This instruction manual explains how to handle, connect, and adjust this product.

We are sure that you will be satisfied with this product because this product has been manufactured and inspected in accordance with the strict quality control standards. In case of trouble such as damage during transportation, please contact your dealer or us as soon as possible.

### ○Package Includes

- Arithmetic and logic unit 1 unit
- Socket 1 piece

## 1. Product Outline

This unit is a small type plug-in converter designed to convert two direct current or voltage signals into a direct current or voltage signal that depends on various arithmetic processes provided to the inputs including addition and subtraction.

This product is a digital type CPU-equipped arithmetic and logic unit. The dedicated setting tool of the unit allows users to change the primary input range, secondary input range, output range, arithmetic item, arithmetic expression, and parameters and perform monitoring as well as provide a simulated input/output in the field.

\* The WSPA-specific setting tool and dedicated USB cable are separately required to change the settings of this product. Refer to the instruction manual for the WSPA setting tool for further information.

## 2. Functions and Features

- The primary input range, secondary input range, output range, arithmetic item, arithmetic expression, and parameters are changeable at your choice.
- Up to 5 arithmetic processes available by multi-computing system.
- Realization of 5-year guarantee owing to long life design
- Universal power supply supported
- CE Marking compliance
- RoHS Directive compliance

## 3. Cautions

1) When this product is used as a CE Directive-compliant item:

- This product complies with Installation Category II, Pollution Degree 2, and Maximum Operating Voltage of 300 volts required by CE Directive. Basic insulation is provided for insulation capability between power supply terminal and input/output of signals. Make sure that the insulation class of this product meets the required specification before installation.
- Follow the definition that this product is designed to be installed in a control panel.

- This product shall be used at an altitude equal to or below 2000 meters.
- Appropriate space and creeping distance shall be provided. Inappropriate wiring may revoke compliance with CE Marking.

CE Directive: Electromagnetic Compatibility Directive

EMI EN61000-6-4

EMS EN61000-6-2

The wiring length should be not more than 30 m.

Low Voltage Directive EN61010-1

RoHS Directive EN50581

- Insulation resistance:  
Among Input-primary output-secondary output-power supply terminal  
100 M ohms or more/500 V DC
- Withstand voltage:  
Among Input-primary output-secondary output-power supply terminal  
2000 V AC for 1 minute

2) Power supply

- Check the rating label.
  - ① For rating: 100-240 V AC  
100-240 V AC±10% (50/60 Hz),  
approx. 5.5 VA (F2AL), approx. 7 VA (F2ALW)
  - ② For rating: 24 V DC  
24 V DC±10%, approx. 100 mA (F2AL),  
approx. 130 mA (F2ALW)
  - ③ For rating: 100-120 V DC  
100-120 V DC±10%, approx. 25 mA (F2AL),  
approx. 30 mA (F2ALW)

3) When handling

- When this product is connected to or disconnected from the socket, be sure to turn off the power and stop the input signal for safety.
- **When a screw on this product is touched or the output control switch is operated, be sure to touch any metal object to release static electricity beforehand.**

4) Installation

- Be sure to use this product indoors.
- If this product is installed in a place with a lot of dust or metal particles, use a dust-proofing case with heat releasing measures to keep this product clean.
- Avoid vibration or shock to this product as much as possible. Failure to observe this may cause trouble.
- Install this product within the operating temperature range of -5 to 55 degrees C.
- Install this product with the operating humidity of 90% RH or less (no freezing, no condensation).
- Do not block the ventilation slot of this product.

5) Wiring

- Keep the power supply line, input line, and output line away from the noise sources, relay drive line, and high frequency line.
- Avoid bundling the line of this product together with the line of superimposed noise and holding the line in the same duct in which the line of superimposed noise is held.

6) Setting change with use of the setting tool

- The setting tool of this product allows users to change the settings of the parameters, and the settings are stored in the internal memory.  
(The same holds true for the output adjustment value. Refer to Section 9 for further information.)  
The write limit to the internal memory is 10,000 times at minimum.

- Do not change settings during operation.
- The settings of this product can be stored in a DAT file. The settings also can be loaded from a DAT file to this product. **However, do not load the settings from the DAT file that was created or edited with use of other than the setting tool to this product. Failure to observe this may cause malfunction or trouble, and then, we cannot guarantee proper operation of this product.**

\* Refer to the instruction manual for the setting tool for further information.

7) Caution other than the above

- It takes 30 minutes to assure full performance of this product even this product can be operated immediately after turning on the power.

### 4. Dimensional Drawing

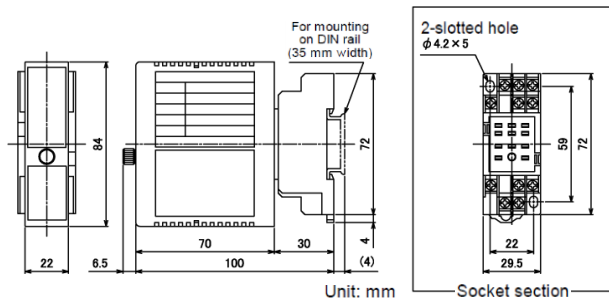

### 5. Circuit Configuration

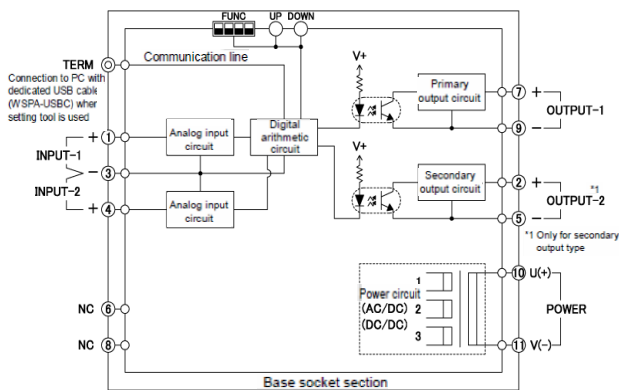

### 6. How to Mount

When mounting the product on a wall, refer to the installation dimension diagram. The diagram below shows the minimum mounting clearance between adjacent units.

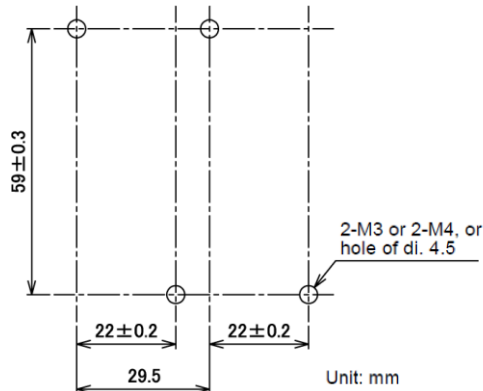

### 7. How to Connect to/Disconnect from DIN Rail

1) How to secure the socket  
Engage the hook on the rear upper side of the socket with the rail with the slider on the bottom side of the socket downward, and press the lower side of the socket in the arrow direction as shown in the drawing to secure the socket.

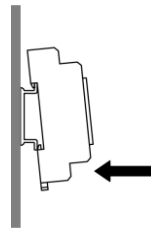

2) How to secure the main unit to the socket  
Position the main unit so that the characters in the front label can be read in the appropriate direction, press the main unit into the socket, and screw the main unit to secure it.

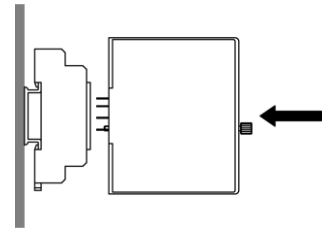

3) How to disconnect the main unit from the socket  
Loosen the screws that secure the main unit, and pull the unit out in a straight line.

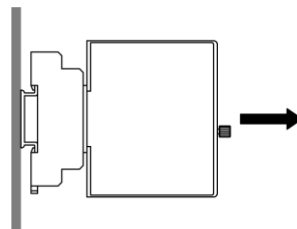

4) How to disconnect the socket from the socket  
Put a flat head screwdriver into the slider slot of the socket and pull the lower side of the socket in the arrow direction ② while pulling the screwdriver in the arrow direction ①.

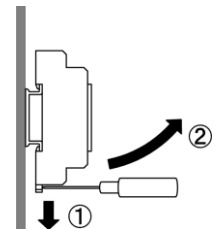

### 8. How to Connect

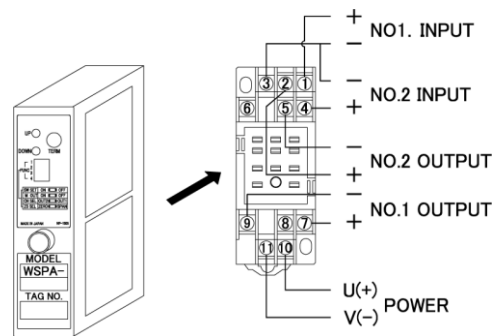

Terminal No.	Sign	Description	
1	INPUT1 +	These terminals receive the specified input signals.	
3	COM -		
4	INPUT2 +		
2	No.2 OUTPUT +	Signals are provided in accordance with the input/output specifications. (*1)	
5	OUTPUT -		
6	NC	No connection	
7	No.1 OUTPUT +	Signals are provided in accordance with the input/output specifications.	
9	OUTPUT -		
8	NC	No connection	
10	POWER	U(+)	Connect the rated voltage power supply.
11		V(-)	

\*1 NC (no connection) for F2AL  
\* No line shall be connected to NC.

## 9. How to Adjust Output

We have already performed output adjustment in accordance with your requests at your order. Therefore, no output adjustment is required if you operate this product within your requested specifications. If matching with devices to be connected or regular calibration is required, follow the steps below.

For calibration, use signal sources (including a standard voltage/current generator) and measuring instruments (including a voltmeter and an ammeter) the tolerances of both of which are more than 10 times that of this product and wait for 30 minutes or more after turning on the power.

Output adjustment is performed with the setting switch on the front side of this product.

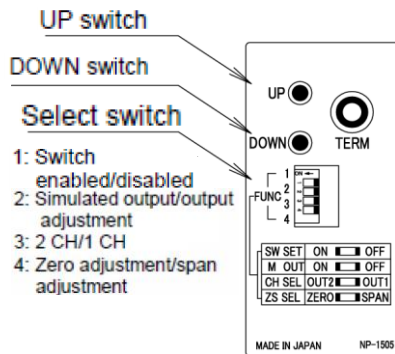

○ How to adjust

① Set the selection switch 1 (SW SET) to ON.

This action enables switch operation.

**If the setting tool is connected, communication is shut off.**

② Set the selection switch 2 (M OUT) to OFF.

③ Set the selection switch 4 (ZS SEL) to ZERO.

Use the UP or DOWN switch to adjust the output to 0% when a 0%-equivalent input is provided and the select switch 3 (CH SEL) is set to OUT1 or OUT2.

④ Set the selection switch 4 (ZS SEL) to SPAN.

Use the UP or DOWN switch to adjust the output to 100% when a 100%-equivalent input is provided and the select switch 3 (CH SEL) is set to OUT1 or OUT2.

⑤ Provide a 0%-equivalent input signal again to make sure that the output is 0%.

If the output deviates, repeat the steps □ and □.

⑥ Set the selection switch 1 to OFF after completion of adjustment.

At this moment, the adjusted values are written into the internal memory and switch operation becomes disabled.

\* The adjusted values are written into the internal memory and turning on or off the power does not clear the values. To restore the settings to factory defaults, use the setting tool to initialize the settings.

The write limit to the internal memory is 10,000 times at minimum.

\* If the power is turned off during adjustment, the adjusted values are not written into the internal memory.

\* approximately  $\pm 10\%$  fs.

## 10. Simulated Output Function

This product is equipped with the simulated output function to conduct tests including connection test.

The simulated output is performed with the setting switch on the front side of this product. (Refer to the drawing in Section 9 for the switch position.)

○ Simulated output procedure

① Set the selection switch 1 (SW SET) to ON.

This action enables switch operation.

**If the setting tool is connected, communication is shut off.**

② Set the selection switch 2 (M OUT) to ON.

③ The simulated output is provided to the channel selected with the selection switch 3 (CH SEL). (An output according to an input is provided to the unselected channel.)

The simulated output value varies with unipolar or bipolar setting.

Use of the UP and DOWN switches provides users with 3 steps of outputs.

Unipolar: (DOWN) 0%  $\Leftrightarrow$  50%  $\Leftrightarrow$  100% (UP)

Bipolar: (DOWN) -100%  $\Leftrightarrow$  0%  $\Leftrightarrow$  100% (UP)

④ Set the selection switch 1 to OFF after completion of adjustment.

## 11. Operation beyond Specifications

1) Excessive input

If an input signal beyond the upper limit is provided, the output signal increases almost in proportion to the input until approximately 120% fs of scaling setting. But even if an excessive input signal is provided more, the output signal does not increase any more.

2) Insufficient input

The output is described below when an input signal below the lower limit is provided.

(a) For unipolar setting, the output signal decreases almost in proportion to the input until approximately -20% fs of scaling setting. But even if an insufficient input signal is provided more, the output signal does not decrease any more.

(b) For bipolar setting, the output signal decreases almost in proportion to the input until approximately -120% fs of scaling setting. But even if an insufficient input signal is provided more, the output signal does not decrease any more.

3) Load beyond specifications

(a) For current output, if the input exceeds the "range of allowable load resistance", the output is provided almost in proportion to the input until the voltage between the output terminals becomes approximately 15 volts. But if the output becomes larger, the output is saturated resulting in larger error.

(b) For voltage output, if the input falls below the "range of allowable load resistance", the output is saturated resulting in larger error.

## 12. PC Settings

The dedicated setting tool of this product allows users to specify the input/output parameters listed below.

Refer to the instruction manual for the setting tool for further information.

(Refer to the instruction manual for the setting tool also for the settable arithmetic function.)

Password	4 one-byte characters
Comment	16 one-byte characters (8 two-byte characters)
Computing range	Selection between unipolar (0 to 100%) and bipolar (-100 to 100%) for input/output signal processing (Default: unipolar)
Input scaling (Input % range adjustment)	Any value within input range ( $\pm 120\%$ fs)
Input filter	Use or nonuse of moving average processing (Default: use)
Input low level cut	Low level cut value of input signal in % (None or 0.00 to 120.00%) (Default: none) *Disabled at bipolar setting
Ratio and bias (Functions ①,② and default arithmetic setting)	Output in alignment relative to input Specifying ratio (-9.999 to 9.999) and bias (-999.99 to 999.99) (Default: ratio of 0.500 and bias of 0.00)
Addition and subtraction (Function ⑤ default arithmetic setting)	Output resulting from adding to or subtracting from input Specifying coefficient (-1000.0 to 1000.0) for each input (Default: 100.0)
Output scaling (Output % range adjustment)	Any value within output range Voltage: $\pm 120\%$ fs of output range Current: -20 to +120% fs of output range
Output low level cut	Low level cut value of output in % (None or 0.00 to 120.00%) (Default: none) * Disabled at bipolar setting
Startup delay time	Period from power-on to output start (0 to 99 sec.) (Default: 0)
Simulated input/output	Simulated input/output in % or real quantity
Data monitor	Input/output monitoring in % and real quantity (This operation also can be performed at settings.)
Initialization	Restored to factory defaults

\* The settings can be stored in the flash memory located in the converter main unit. The write limit to the memory is 10,000 times at minimum.

(Retention period: 100 years at minimum)

\* Do not write to the memory during operation.

(The product may unstably operate during writing.)

\* The numbers within the parentheses such as function ① and function ② indicate the setting position in "Conversion/Arithmetic Setting" for the setting tool. Refer to the instruction manual for the setting tool for arithmetic items and operator.

## 13. Guarantee

This product is guaranteed for 5 years after delivery. If a failure occurs under normal operation during the guaranteed period, contact your dealer or us as soon as possible.

We will collect the product and repair it free of charge, or replace the product with new one.

We shall not be liable for use of this product that was disassembled or modified or under abnormal conditions.